

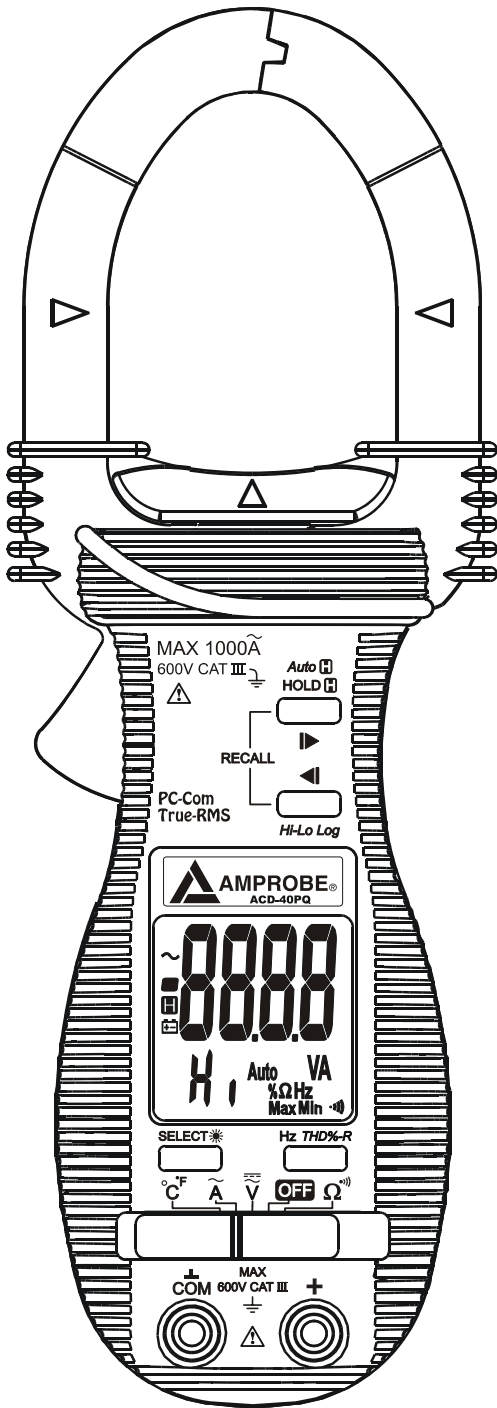

# AMPROBE®



## USER'S MANUAL

ACD-16 Pro

ACD-16 TRMS Pro

ACD-40PQ

## 1) SAFETY

This manual contains information and warnings that must be followed for operating the instrument safely and maintaining the instrument in a safe operating condition. If the instrument is used in a manner not specified by the manufacturer, the protection provided by the instrument may be impaired.

The meter meets the requirements for double insulation to IEC61010-2-032(1994), EN61010-2-032(1995), UL3111-2-032(1999):

Category III 600 Volts ac and dc.

### PER IEC61010 OVERVOLTAGE INSTALLATION CATEGORY

#### *OVERVOLTAGE CATEGORY II*

Equipment of OVERVOLTAGE CATEGORY II is energy-consuming equipment to be supplied from the fixed installation.

Note – Examples include household, office, and laboratory appliances.

#### *OVERVOLTAGE CATEGORY III*

Equipment of OVERVOLTAGE CATEGORY III is equipment in fixed installations.

Note – Examples include switches in the fixed installation and some equipment for industrial use with permanent connection to the fixed installation.

#### *OVERVOLTAGE CATEGORY IV*

Equipment of OVERVOLTAGE CATEGORY IV is for use at the origin of the installation.

Note – Examples include electricity meters and primary over-current protection equipment.

### TERMS IN THIS MANUAL

**WARNING** identifies conditions and actions that could result in serious injury or even death to the user.

**CAUTION** identifies conditions and actions that could cause damage or malfunction in the instrument.

**WARNING**

To reduce the risk of fire or electric shock, do not expose this product to rain or moisture. The meter is intended only for indoor use.

To avoid electrical shock hazard, observe the proper safety precautions when working with voltages above 60 VDC or 30 VAC rms. These voltage levels pose a potential shock hazard to the user.







Inspect test leads, connectors, and probes for damaged insulation or exposed metal before using the instrument. If any defects are found, replace them immediately.

Do not touch test lead tips or the circuit being tested while power is applied to the circuit being measured. To avoid accidentally short circuit of bare (uninsulated) hazardous live conductors or busbars, switch them off before insertion and removal of the current clamp jaws. Contact with the conductor could result in electric shock. Keep your hands/fingers behind the hand/finger barriers that indicate the limits of safe access of the meter and the test leads during measurement.

**CAUTION**

Disconnect the test leads from the test points before changing meter functions.

**INTERNATIONAL ELECTRICAL SYMBOLS**

	Caution ! Refer to the explanation in this Manual
	Caution ! Risk of electric shock
	Earth (Ground)
	Double Insulation or Reinforced insulation
	Fuse
	AC--Alternating Current
	DC--Direct Current

**2) CENELEC Directives**

The instruments conform to CENELEC Low-voltage directive 73/23/EEC and Electromagnetic compatibility directive 89/336/EEC

### 3) PRODUCT DESCRIPTION

This user's manual uses only representative model(s) for illustrations. Please refer specification details for function availability to each model.

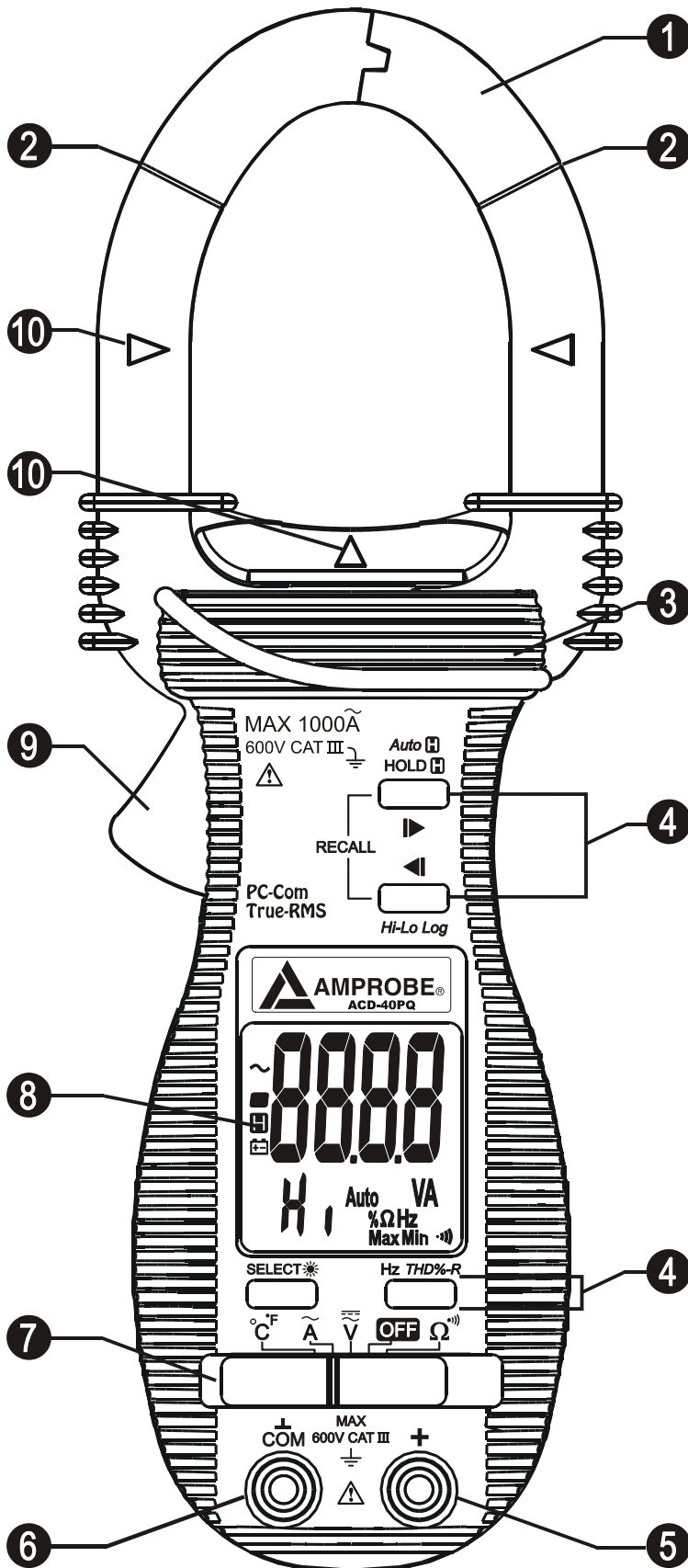

1) Transformer Clamp Jaws for AC current magnetic field pick up

2) Jaw marking lines for ACA position error indication

3) Hand/Finger Barrier to indicate the limits of safe access to the jaws during current measurements

4) Push-buttons for special functions & features

5) Input Jack for all functions EXCEPT non-invasive ACA current function

6) Common (Ground reference) Input Jack for all functions EXCEPT non-invasive ACA current function

7) Slide-switch Selector to turn the power ON/OFF and Select a function

8) LCD display

9) Jaw trigger for opening the transformer clamp jaws

10) Jaw center Indicators, at where best ACA accuracy is specified

## 4) OPERATION

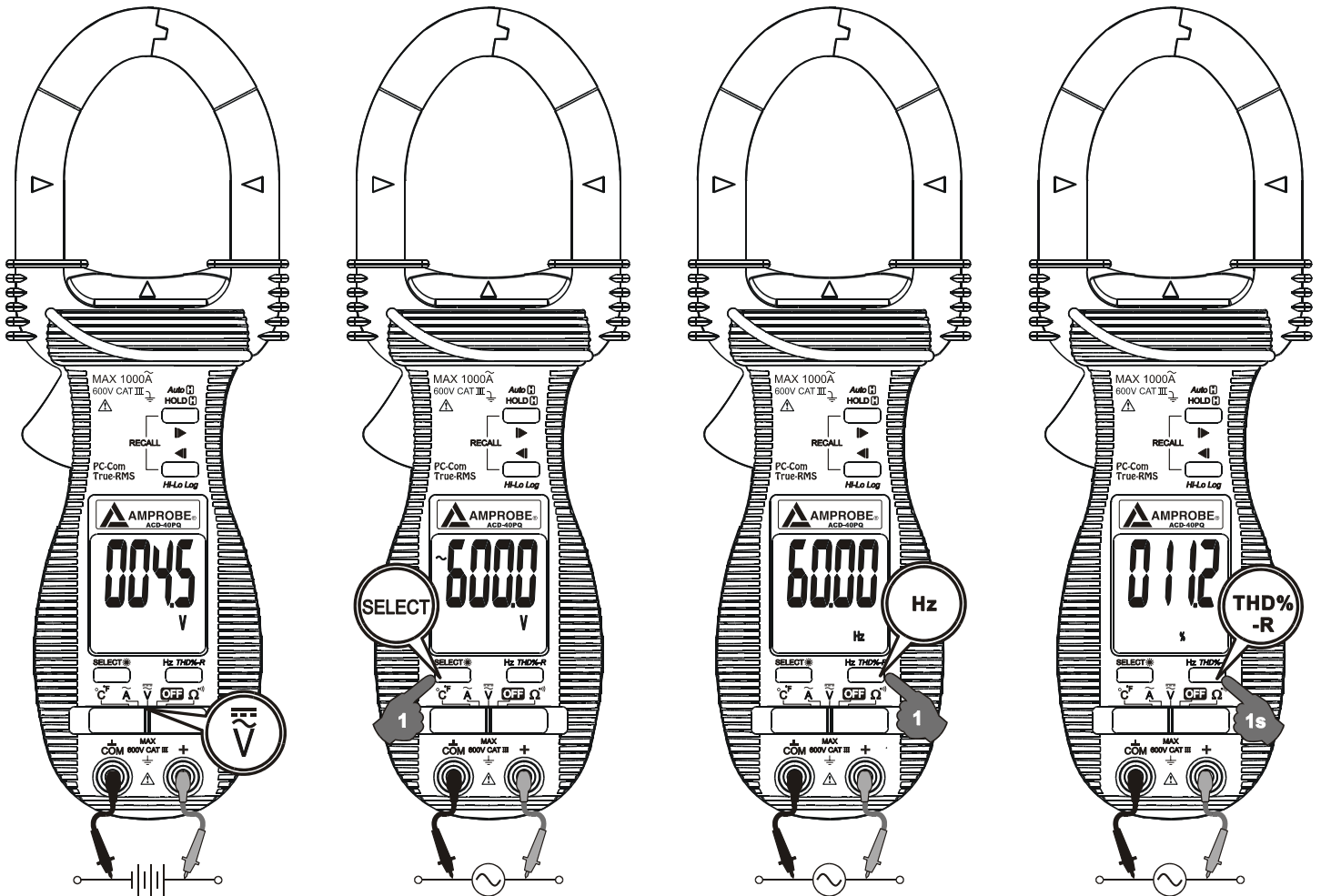

### ACV & DCV functions

Set the slide-switch function-selector to the  $\overline{\sim}$  position. Default at last selected function. Press SELECT button to toggle between ACV and DCV measurement functions. There is no LCD annunciator for DC. LCD annunciator “ $\sim$ ” turns on to indicate AC is selected.

### Line-level Frequency function

When voltage or current function is selected, press Hz button momentarily toggles to Line-level Frequency function. Frequency trigger levels vary automatically with function ranges.

### THD%-R Total Harmonic Distortion - RMS function (ACD-40PQ only)

$$\text{THD\%-R} = (\text{Total Harmonics RMS} / \text{Total RMS}) \times 100\%$$

Total Harmonic Distortion - RMS (THD%-R) is the percentage ratio of the Total Harmonics RMS value to the Total (Overall) RMS value of a voltage or current signal, and is given by the above expression. An ideal sinusoidal waveform has a value of 0 %. A badly distorted sinusoidal waveform may have a much higher THD%-R value of approaching one hundred (100% is the maximum theoretical reading).

When voltage or current function is selected, press and hold **THD%-R** button for one second or more toggles to Total Harmonic Distortion - RMS measurement function. The LCD annunciator “%” turns on.

Note:

Specified accuracy at ACA fundamental > 5A; ACV fundamental > 50V.

The meter displays “---.- %” when ACA fundamental < 1A; ACV fundamental < 8.5V

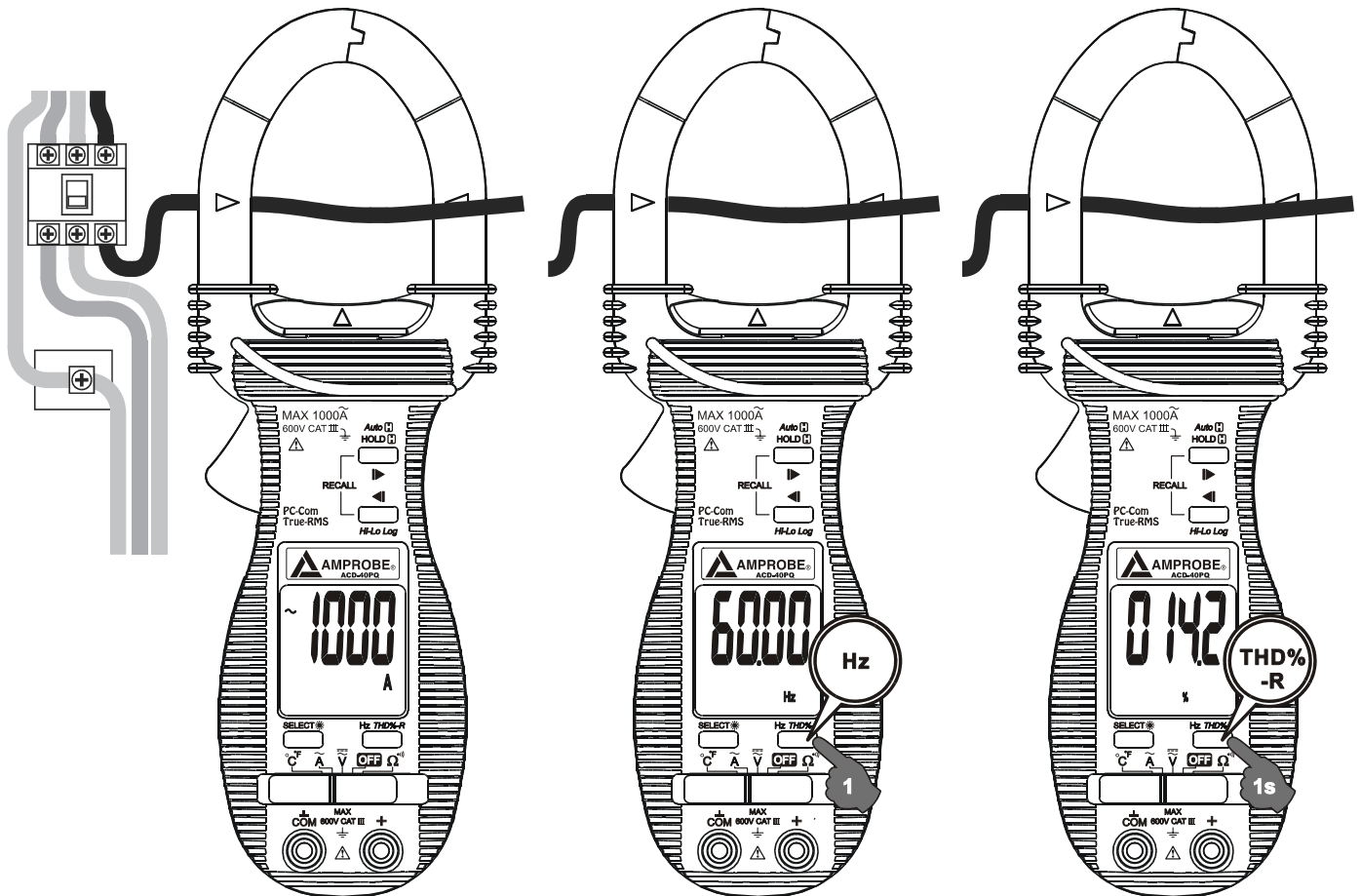

### ACA Current clamp-on function

Set the slide-switch function-selector to the  $\tilde{A}$  position. Inputs are made through the clamp jaws for non-invasive ACA current measurements.

#### CAUTION

- For non-invasive ACA current measurements, press the jaw trigger and clamp the jaws around only one single conductor of a circuit for load current measurement. Make sure the jaws are completely closed, or else it will introduce measurement errors. Enclosing more than one conductor of a circuit will result in differential current (like identifying leakage current) measurement.
- Adjacent current-carrying devices such as transformers, motors and conductor wires will affect measurement accuracy. Keep the jaws away from them as much as possible to minimize influence.

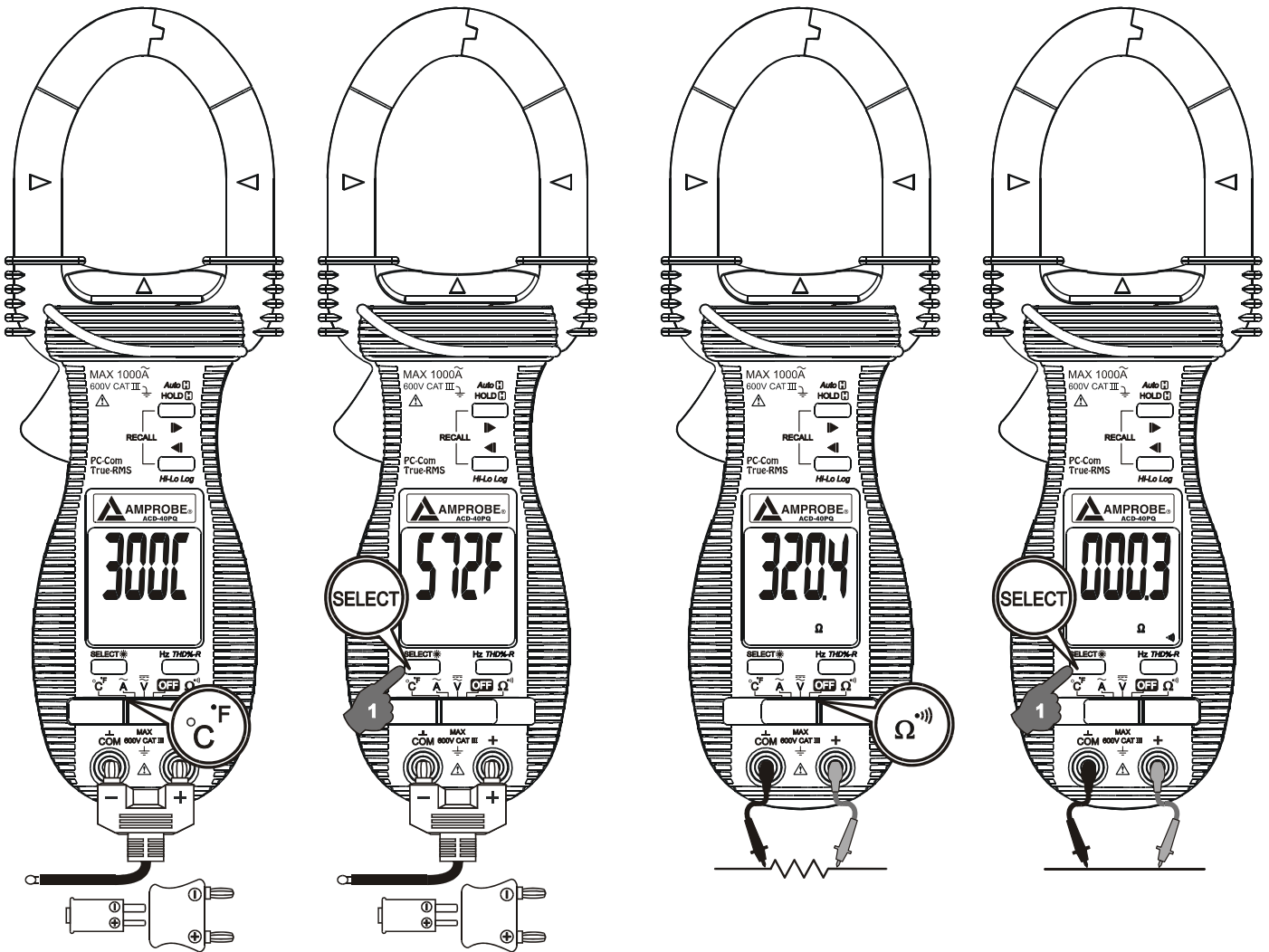

### Temperature function

Set the slide-switch function-selector to the °C/°F position. Default at last selected function. Press SELECT button to toggle between °C and °F measurement functions. Be sure to insert the banana-plug type-K temperature bead probe TPK-59 at correct **+** **-** polarities.

### Ω/•) functions

Set the slide-switch function-selector to the Ω/•) function position. Default at last selected function. Press SELECT button to toggle between Ω and •) measurement functions.

### Hi-Lo Logging mode

Hi-Lo Logging is an innovative feature. It minimizes product cost for maximum monitoring speed and period making field monitoring simpler and more affordable. Hi-Lo Logging captures the most important surges (Hi) & sages (Lo) using one-minute intervals. That is, the meter uses its highest update rate to compare and capture the highest and lowest readings in every one-minute time interval. It can log up to 5400 pairs of Hi/Lo readings and thus 5400 minutes of total logging period.

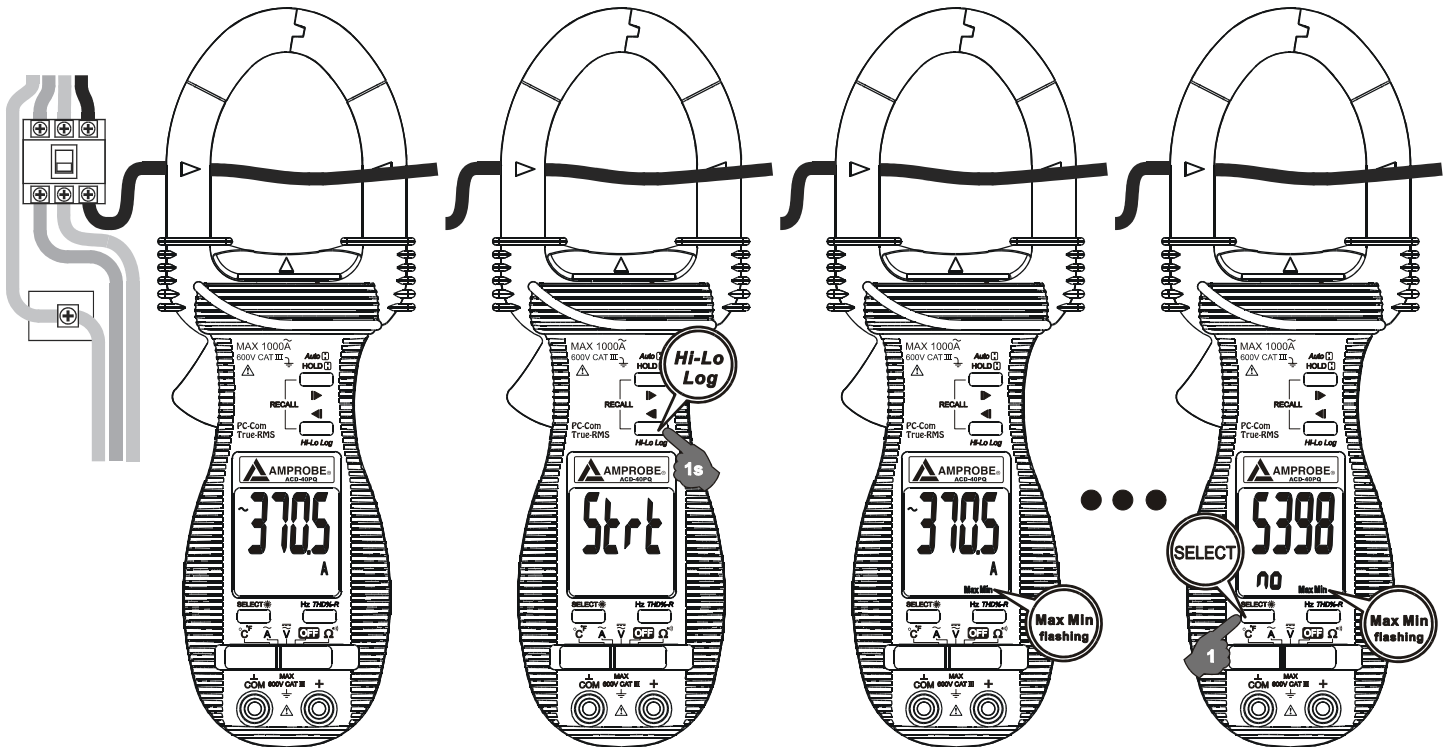

Press and hold the “Hi-Lo Log” button for one second or more to start “Start” a new Hi-Lo Logging session. All previously logged data is erased! Annunciators “Max Min” flashes and real-time measurement readings are being displayed. Press SELECT button momentarily toggles to display logged data item number (number of one-minute time intervals). “no” displays in the secondary display.

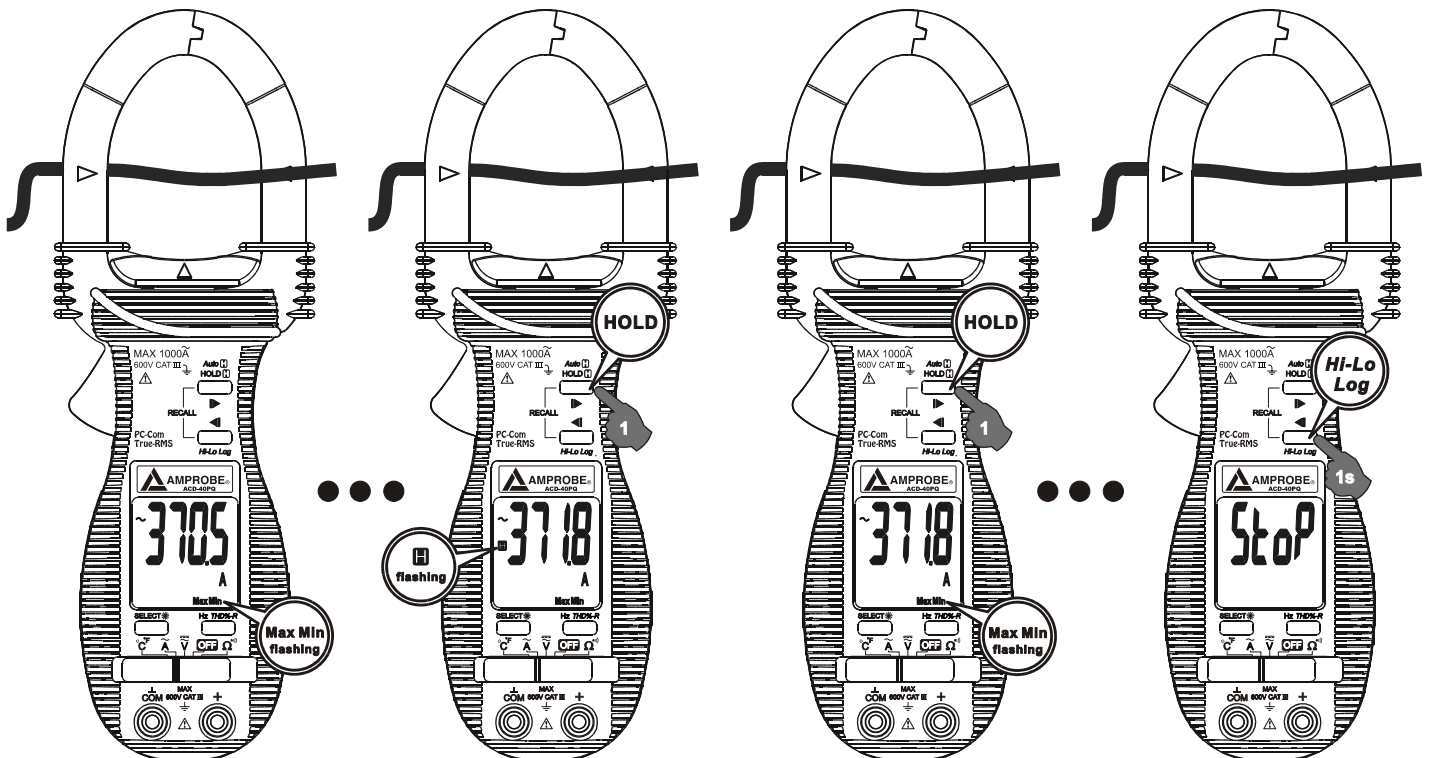

Press the HOLD button momentarily to pause. The LCD annunciator “HOLD” flashes. Press the HOLD button momentarily again to continue. Press and hold the “Hi-Lo Log” button for one second or more again to stop “Stop” and end the Hi-Lo Logging session. The meter can now be switched off.



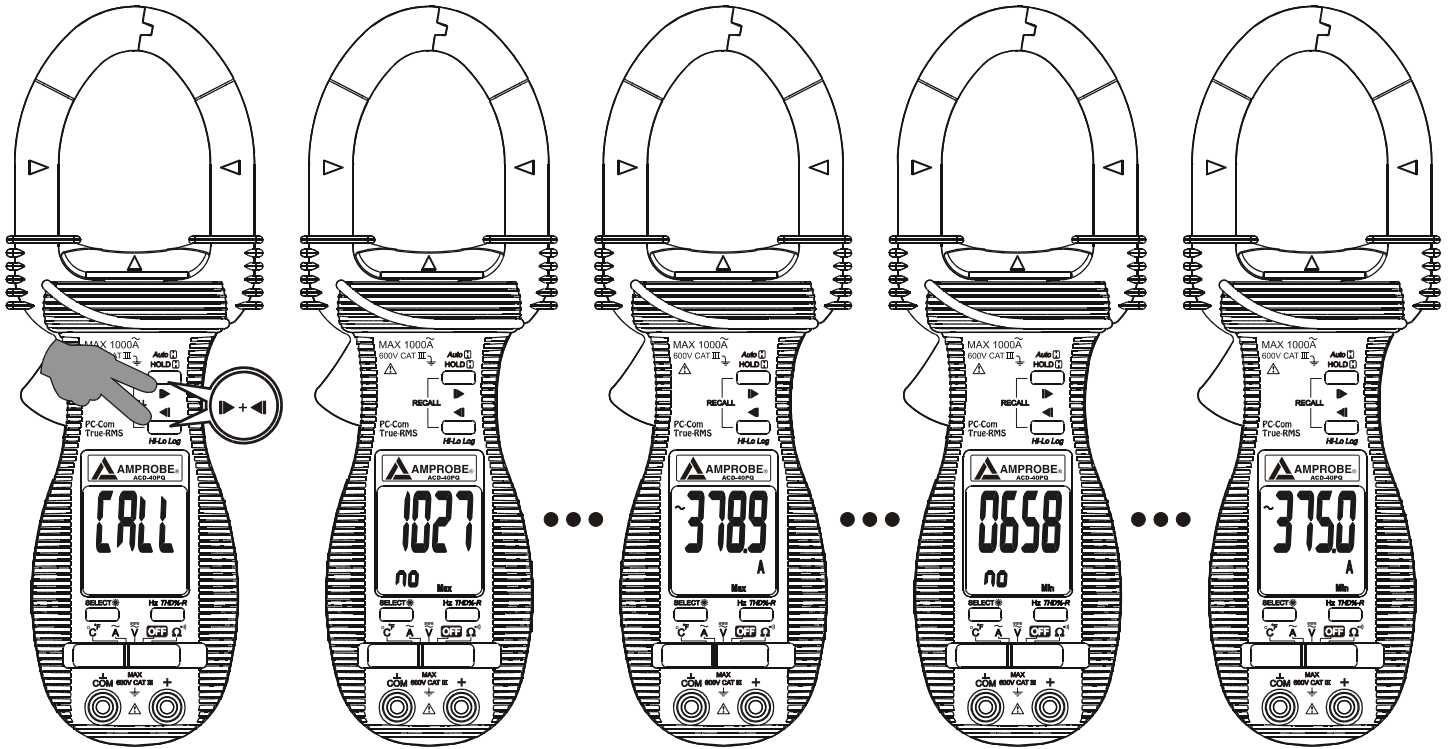

To recall the data, switch on the meter, then press the forward “▶” and backward “◀” arrow buttons at the same time to recall “CALL” the logged data. The meter displays in turn the absolute maximum item number, absolute maximum reading, absolute minimum item number, and then absolute minimum reading (of the whole logging period).

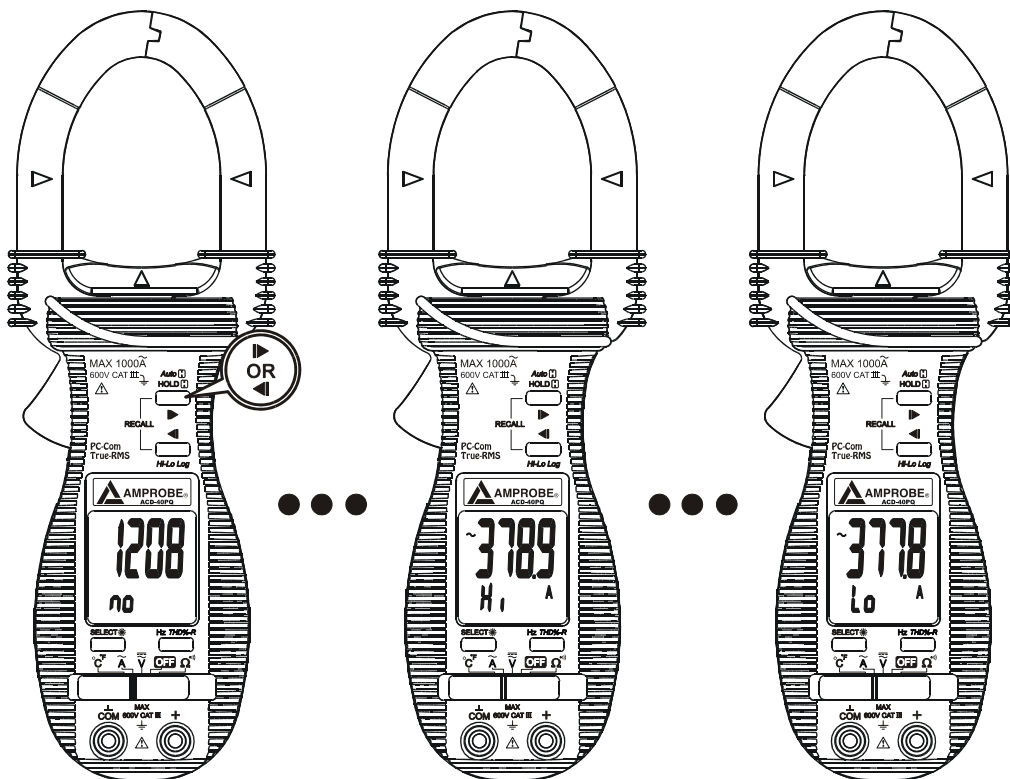

Press the forward “▶” (or backward “◀”) arrow button momentarily to read the next logged data item. The meter displays in turn the one-minute item interval number “no” (the count of one-minute time intervals), Hi-reading “Hi” (the highest reading), and then Lo-reading “Lo” (the lowest reading) of that one-minute item interval. Press-and-hold the



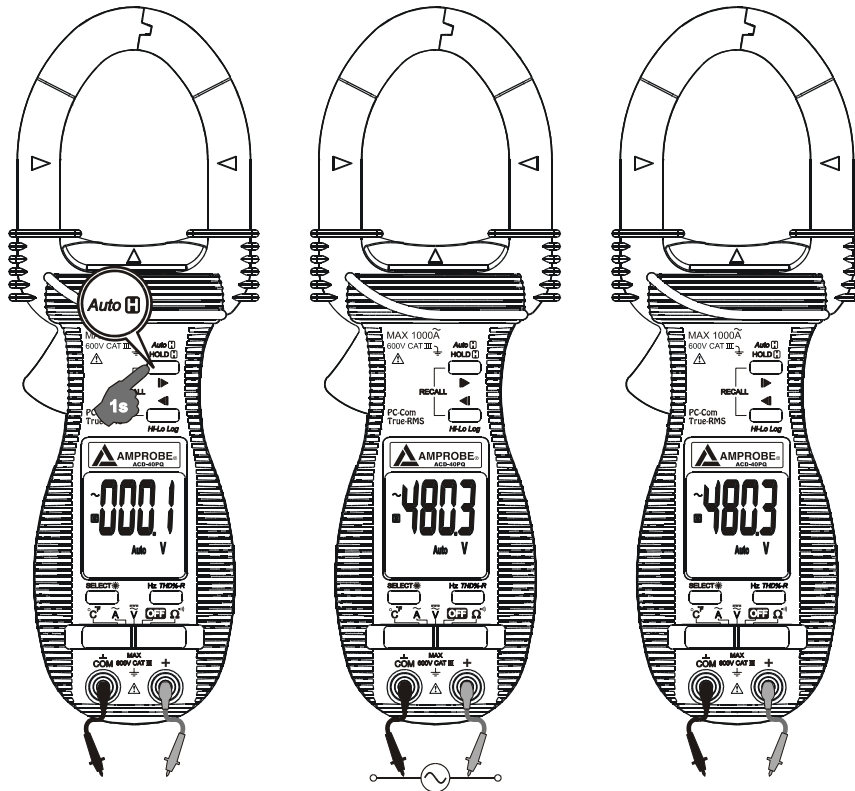

button can quickly scroll the logged items. The meter gives short beeps when the last (or the first) item is reached.

Note:

1. When the meter's memory is full or the meter battery is low, the meter will stop (end) the Hi-Lo logging session and go back to the normal measuring mode.
2. The data is stored to the non-volatile memory shortly after every one-minute item interval to maximize data safety. However, the end-of-data sign can be stored only after the Hi-Lo logging session is ended with a session stop "Stop". Therefore, always stop "Stop" the Hi-Lo logging properly before sliding the slide-switch function-selector to the next function position.
3. After the Hi-Lo logging session has ended, you can switch off the meter for transportation, storage, or even battery changing. The logged data can also be downloaded to PC computers through the optional purchase RS232 KIT2 interface kit. Also see RS232C PC computer interface capabilities section.





### Auto feature

The **Auto ** (Automatic-Hold) feature automatically captures and displays significant stable readings. Press and hold the **Auto ** button for one second or more to toggle to the **Auto ** mode. The LCD annunciators "Auto" & "" turn on.

### WARNING

To avoid electric shock hazard, do not use the **Auto ** (Automatic-Hold) mode to determine if a circuit is live. Unstable readings will not be captured and displayed.

### HOLD feature

The Hold feature freezes the display for later viewing. Press the **HOLD ** button momentarily to toggle to the Hold mode. The annunciator "" turns on.

### Display Backlight (model ACD-16 TRMS & ACD-40PQ only)

Press the SELECT button for 1 second or more to toggle the display backlight on and off.

### Auto Power Off (APO)

The meter turns off after approximately 16 minutes of neither switch nor button activity. To wake up the meter from APO, slide the function-selector to other positions and back on again. Always turn the function-selector to OFF when the meter is not in use.

### Disabling Auto-Power-Off (APO)

Press-and-hold the HOLD button while sliding the function-selector to a (designated) function-selector position. This disables the Auto-Power-Off feature of the functions on that particular function-selector position. The LCD displays "SLP-" & "OFF." to confirm activation right after the HOLD button is released. *Slide the function-selector to any other positions afterwards resumes Auto-Power-Off feature.*

### RS232C PC computer interface capabilities

The instrument is equipped with an optical isolated data output port at the bottom case near the battery compartment. Optional purchase PC interface kit RS232 KIT2 (including Optical Adapter Back, RS232 Cable & Bs13x Software CD) is required to connect the meter to PC computer thru RS232C protocol. The RS232C Data Recording System software Bs13x includes a digital meter, an analog meter, a comparator meter, and a Data Graphical recorder. Refer to the README file comes with the interface kit for further details.

## 5) MAINTENANCE

### **WARNING**

To avoid electrical shock, disconnect the meter from any circuit, remove the test leads from the input jacks and turn OFF the meter before opening the case. Do not operate with open case.

### Trouble Shooting

If the instrument fails to operate, check batteries and test leads etc., and replace as necessary. Double check operating procedure as described in this user's manual

If the instrument voltage-resistance input terminal has subjected to high voltage transient (caused by lightning or switching surge to the system) by accident or abnormal conditions of operation, the series fusible resistors will be blown off (become high impedance) like fuses to protect the user and the instrument. Most measuring functions through this terminal will then be open circuit. The series fusible resistors and the spark gaps should then be replaced by qualified technician. Refer to the LIMITED WARRANTY section for obtaining warranty or repairing service.

## Cleaning and Storage

Periodically wipe the case with a damp cloth and mild detergent; do not use abrasives or solvents. If the meter is not to be used for periods of longer than 60 days, remove the batteries and store them separately

## Battery replacement

The meter uses standard 1.5V AAA Size (NEDA 24A or IEC LR03) battery X 2  
Loosen the 2 captive screws from the battery cover case. Lift the battery cover case. Replace the batteries. Replace battery cover case. Re-fasten the screws.

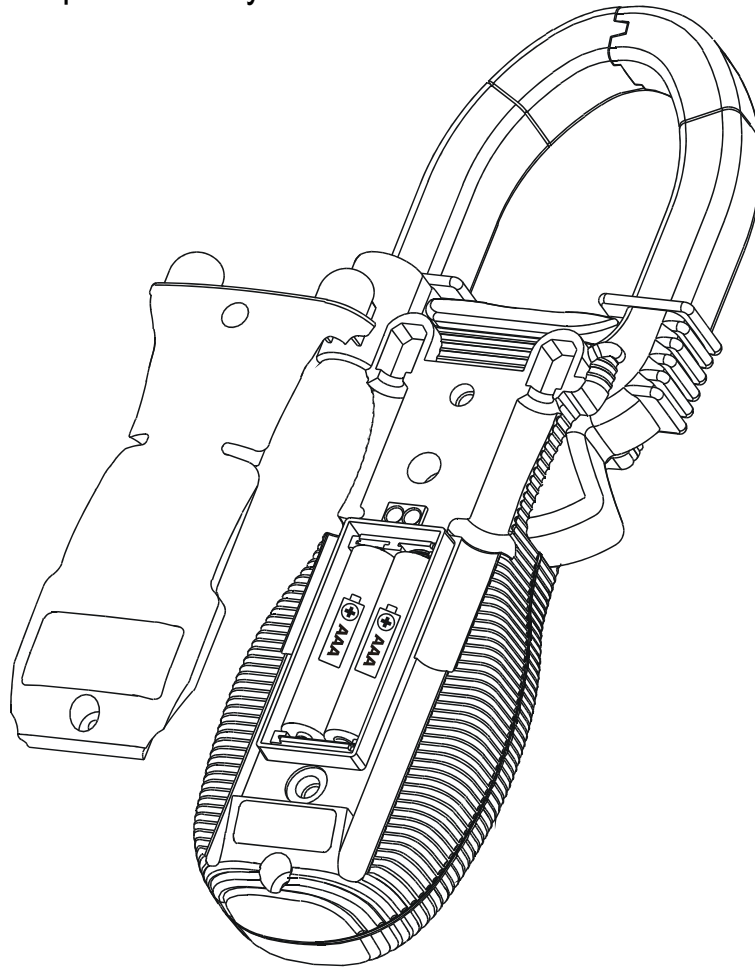

## 6) Specifications

### General Specifications

#### Display :

Voltage functions: 6000 counts LCD display

Ohm & Hz functions: 9999 counts LCD display

ACA clamp-on function: 4000 counts LCD display

#### Update Rate :

Voltage, ACA clamp-on, Ohm & Temperature functions: 4 per second nominal

Hz function: 2 per second nominal

#### Polarity : Automatic

Low Battery : Below approx. 2.4V

Operating Temperature : 0°C to 40°C

**Relative Humidity** : Maximum relative humidity 80% for temperature up to 31°C decreasing linearly to 50% relative humidity at 40°C

**Altitude** : Operating below 2000m

**Storage Temperature** : -20°C to 60°C, < 80% R.H. (with battery removed)

**Temperature Coefficient** : nominal  $0.15 \times (\text{specified accuracy}) / ^\circ\text{C}$  @ (0°C -18°C or 28°C -40°C), or otherwise specified

**Sensing** : Average sensing for model 131; True RMS sensing for model 132 & 135

**Safety** : Meets IEC61010-2-032(1994), EN61010-2-032(1995), UL3111-2-032(1999).

Measurement Category III 600 Volts ac & dc

**Transient protection** : 6.5kV (1.2/50µs surge) for all models

**Pollution degree** : 2

**E.M.C.** : Meets EN61326(1997, 1998/A1), EN61000-4-2(1995), and EN61000-4-3(1996)

In an RF field of 3V/m:

Total Accuracy = Specified Accuracy + 45 digits

Performance above 3V/m is not specified

**Overload Protections** :

ACA Clamp-on jaws : AC 1000A rms continuous

+ & COM terminals (all functions) : 600VDC/VAC rms

**Power Supply** : standard 1.5V AAA Size (NEDA 24A or IEC LR03) battery X 2

**Power Consumption** :

Voltage & ACA functions: 3.5mA typical

Ohm & Temperature functions: 4mA typical

**APO Timing** : Idle for 16 minutes

**APO Consumption** : 10µA typical

**Dimension** : L224mm X W78mm X H40mm

**Weight** : 224 gm approx

**Jaw opening & Conductor diameter** : 45mm max

**Special features** : THD%-R Total harmonic distortion-RMS (ACD-40PQ only); Display

Backlight ACD-16 TRMS & ACD-40PQ only); Auto-Hold; Display Hold; On screen

stand-alone Hi-Lo logging (5400 minutes) at sampling speed of faster than:

20 per second for Voltage & ACA functions

4 per second for Ohm & Temperature functions

2 per second for Hz function

**Accessories** : Test leads (MTL-90B), batteries installed, user's manual, TPK-59 banana plug type-K thermocouple & soft carrying pouch

**Optional accessories** : RS-232 KIT2 interface kit.

**Electrical Specifications**

Accuracy is  $\pm(\% \text{ reading digits} + \text{number of digits})$  or otherwise specified, at 23 °C  $\pm 5$  °C & less than 75% R.H.

True RMS Models ACD-16TRMS & ACD-40PQ ACV & ACA clamp-on accuracies are specified from 5% to 100% of range or otherwise specified. Maximum Crest Factor are as specified below, and with frequency spectrums, besides fundamentals, fall within the meter specified AC bandwidth for non-sinusoidal waveforms. Fundamentals are specified at 50Hz and 60Hz.

### AC Voltage

RANGE	Accuracy
50Hz / 60Hz	
600.0V	1.0% + 5d
45Hz ~ 500Hz	
600.0V	1.5% + 5d
500Hz ~ 3.1kHz (model 132 & 135 only)	
600.0V	2.5% + 5d

CMRR : >60dB @ DC to 60Hz,  $R_s=1k\Omega$

Input Impedance:  $2M\Omega$ , 30pF nominal

True RMS models Crest Factor:

< 2.3 : 1 at full scale & < 4.6 : 1 at half scale

### DC Voltage

RANGE	Accuracy
600.0V	0.5% + 5d

NMRR : >50dB @ 50/60Hz

CMRR : >120dB @ DC, 50/60Hz,  $R_s=1k\Omega$

Input Impedance:  $2M\Omega$ , 30pF nominal

### THD%-R<sup>1)</sup> (model 135 only)

RANGE	Harmonic order	Accuracy <sup>2)</sup>
0.0% ~99.9%	Fundamental	1.5% of Reading + 6d
	2nd ~ 3rd	5.0% of Reading + 6d
	4th ~ 10th	2.5% of Reading + 6d
	11th ~ 51st	2.0% of Reading + 6d

<sup>1)</sup>THD-R is defined as: (Total Harmonic RMS / Total RMS) x 100%

<sup>2)</sup>Specified accuracy @ ACA fundamental > 5A ; ACV fundamental > 50V

### Ohms

RANGE	Accuracy
999.9 $\Omega$	1.0% + 6d

Open Circuit Voltage : 0.4VDC typical

## Audible Continuity Tester

Audible threshold: between  $10\Omega$  and  $300\Omega$ .

Response time:  $250\mu\text{s}$

### Frequency

Range	Accuracy
5.00Hz ~ 500.0Hz	0.5%+4d

Sensitivity (Sine RMS)

40A range: > 4A

400A range: > 40A

1000A range: > 400A

600V range: > 30V

### Temperature

RANGE	Accuracy <sup>1)</sup>
-50°C ~ 300°C	2.0% + 3°C
-58°F ~ 572°F	2.0% + 6°F

<sup>1)</sup>Add 3°C (or 6°F) to specified accuracy @ -20°C ~ -50°C (or @ -4°F ~ -58°F)

Type-K thermocouple range & accuracy not included

### ACA Current (Clamp-on)

RANGE	Accuracy <sup>1) 2) 3)</sup>
50Hz / 60Hz	
40.00A, 400.0A, 1000A	1.0% + 5d
45Hz ~ 500Hz	
40.00A, 400.0A	2.0% + 5d
1000A	2.5% + 5d
500Hz ~ 3.1kHz (ACD-16TRMS Pro & ACD-40PQ only)	
40.00A, 400.0A	2.0% + 5d
1000A	2.5% + 5d

True RMS models Crest Factor:

< 2.5 : 1 at full scale & < 5.0 : 1 at half scale for 40.00A & 400.0A ranges

< 1.4 : 1 at full scale & < 2.8 : 1 at half scale for 1000A range

<sup>1)</sup>Add 8d to specified accuracy while reading is below 10% of range

<sup>2)</sup>Induced error from adjacent current-carrying conductor: < 0.06A/A

<sup>3)</sup>Specified accuracy is for measurements made at the jaw center. When the conductor is not positioned at the jaw center, position errors introduced are:

Add 1% to specified accuracy for measurements made WITHIN jaw marking lines (away from jaw opening)

Add 4% to specified accuracy for measurements made BEYOND jaw marking lines (toward jaws opening)

## **LIMITED WARRANTY**

Congratulations! Your new instrument has been quality crafted according to quality standards and contains quality components and workmanship. It has been inspected for proper operation of all of its functions and tested by qualified factory technicians according to the long-established standards of our company. Your instrument has a limited warranty against defective materials and/or workmanship for one year from the date of purchase provided that, in the opinion of the factory, the instrument has not been tampered with or taken apart. Should your instrument fail due to defective materials, and/or workmanship during this one year period, a no charge repair or replacement will be made to the original purchaser. Please have your dated bill of sale, which must identify the instrument model number and serial number and call the number listed below:

### **Repair Department**

ATP – Amprobe

Phone: 954-499-5400

Toll Free: 800-327-5060

Fax: 866-287-7222

Website: [www.Amprobe.com](http://www.Amprobe.com)

Please obtain an RMA number before returning product for repair. Outside the U.S.A. the local representative will assist you. Above limited warranty covers repair and replacement of instrument only and no other obligation is stated or implied.



[www.Amprobe.com](http://www.Amprobe.com)



PRINTED ON RECYCLABLE PAPER, PLEASE RECYCLE  
COPYRIGHT © MMV Btc, ALL RIGHTS RESERVED  
PRINTED IN TAIWAN