

AT-4000CON *Advanced Tracer*



User's Manual

Amprobe thanks you for purchasing the AT-4000CON Advanced Tracer. For your safety, please read this instruction manual in its entirety.



LIMITED WARRANTY

Congratulations! Your new instrument has been quality crafted according to quality standards and contains quality components and workmanship. It has been inspected for proper operation of all of its functions and tested by qualified factory technicians according to the long-established standards of our company.

Your instrument has a limited warranty against defective materials and/or workmanship for one year from the date of purchase provided that, in the opinion of the factory, the instrument has not been tampered with or taken apart.

Should your instrument fail due to defective materials, and/or workmanship during this one year period, a no charge repair or replacement will be made to the original purchaser. Please have your dated bill of sale, which must identify the instrument model number and serial number and call the number listed below:

Repair Department

Phone:954-499-5400 / 800-327-5060

Fax:866-287-7222

Website:www.Amprobe.com

**Please obtain an RMA number before
returning product for repair.**

*Outside the U.S.A. the local representative will assist you.
Above limited warranty covers repair and replacement of
instrument only and no other obligation is stated or implied.*

Table of Contents

Precautions & Introduction.....	02
Product Description.....	03
Application Notes.....	08
Using the R-4000CON.....	08
Using the T-4000.....	09
A2202 Clamp-on Transmitter Accessory.....	12
Finding Opens.....	13
Finding Ground Faults.....	14
Tracing Wires in Conduit.....	15
Locating Circuit Breakers or Fuses.....	15
Tracing Wires.....	16
Maintenance.....	18
Replacement Parts.....	19
Troubleshooting.....	19
Specifications.....	20

PRECAUTIONS FOR PERSONAL AND INSTRUMENT PROTECTION

IMPORTANT:

1. Before using any electrical instrument, it should be checked to make certain it is operating properly.
2. In many instances, you will be working with dangerous levels of voltages and/or current, therefore, it is important that you avoid direct contact with any uninsulated, current carrying surfaces. Appropriate insulated gloves and protective clothing should be worn.
3. Before attaching any of the conductors, make sure the voltage present is not beyond the range of the instrument.
4. When not in use, keep the instruments in their carrying case.
5. When the R-4000CON or the T-4000 will not be used for a period of time, remove the battery to prevent leakage in the instrument.

INTRODUCTION

AMPROBE ATP SPX is dedicated to designing, manufacturing and marketing high quality, reliable instruments for the skilled professional. The AMPROBE ATP SPX current tracer has a history of providing safe, reliable operation in tracing energized wires, locating circuit breakers and locating wires shorted to the ground. The AMPROBE ATP SPX open tracer has the capability of tracing unenergized wires, locating open breakers and locating open wires.

The AT-4000CON Wire Tracer Upgrade System combines both the current tracing CT-100 and the AT-2000 series into one versatile tool providing the ability to solve virtually all your tracing problems. In addition to the above features, the receiver provides a non position sensitive when tracing wire and the transmitter provides a visual indication to the user when the traced line is energized. The level of the signal transmission is also indicated on the LCD of the transmitter unit.

Having confidence in an instrument is an important part of using the instrument. All applications are different and unique. **An understanding of the system's operation could mean the difference between several minutes or several hours on the job.**

Please read this manual carefully. Take the time to learn how the instrument operates. The operation is user friendly and easy to learn. Test it in a variety of situations. You will soon have the confidence to use it on a daily basis to solve problems that were previously unsolvable.

AT-4000CON PRODUCT DESCRIPTION

The AT-4000CON consists of two units:

T-4000 Transmitter (32.768KHZ, 9-600 volts AC or DC)

R-4000CON Receiver(Non-position sensitive, Open / Short Tracing)

Unit Description

R-4000CON Receiver:

It has two built in detectors that are tuned to pick up the 32.768Khz signals generated by the T-4000 transmitter. The R-4000CON is designed to display the signal strength to enable quick locating of the conductor carrying the signal.

Fig.1 R-4000CON Receiver



T-4000 Transmitter

When connected to an energized circuit, the T-4000 will filter the low frequencies up to 400Hz and rapidly indicate on the display that the wire is energized. When the user starts the transmission, a combination of signals is injected on top of the 50, 60, or 400Hz that cause a slight, periodic current fluctuation and allows the power line to emit its own, traceable signal. This signal can be detected back to the main generator. However, the signal will not interfere with any sensitive electronic equipment and does not require power interruption. The unit is intrinsically safe and has a 'LOW' signal transmission setting that must be used when tracing GFCI-protected circuits.

When connecting to a circuit as a load, the signal will be present anywhere between the T-4000 and the power source. (Line side or Upstream)- no signal will be present on wiring on the other side of the transmitter(load side or downstream). For example, a transmitter connected to a circuit breaker will produce no signal on that circuit. It will, however, cause a signal to be generated between that panel and the transformer...and beyond. When connecting to an unenergized circuit, the live indication on the display will remain 'OFF'. When the user starts the transmission, the transmitter injects a combination of signals onto the conductor. The signal will travel along the conductor until it ends. There is no difference in the functional mode of the unit when tracing energized circuit and unenergized circuits. On an open line, no current will flow, so the injected signal will present itself as a voltage spike along the wire which is detected by the R-4000CON in the 'OPEN' mode. When the conductor is part of a complete circuit, the voltage causes a current to flow which produces a signal that is detected in the 'SHORT' mode. The T-4000 contains a 9V battery. A 24V input jack accepts the B2024 rechargeable battery or the B2025 110V converter, both use when a very strong signal is necessary. **(Note: When using the battery booster (B2024 or B2025) the unit will work in ultra high "U-HI" mode only. Remove the battery booster to return to normal operation.)**

Fig.2 T-4000 Transmitter



Fig.2 T-4000 Transmitter Continued



"U-HI" - Transmission Ultra High: Battery booster is in use. To return to normal operation, remove the battery booster.

A2202 Clamp-On Transmitter Accessory

Enables the T-4000 to induce its signal onto an unenergized or energized circuit. Plug the A2202 into the T4000 and clamp it around any conductor in an unenergized circuit, or the hot wire in an energized circuit. The signal will be induced on top of the 50,60, or 400Hz frequency which may be present. The AT2201 acts like a 1/2 Volt battery when clamped around a conductor. On a complete circuit this voltage will cause about 80mA of current to flow on top of the whatever frequency is present.

To increase the signal strength, loop the wire around the clamp a few times or use the B2024 battery Pack. The A2202 will allow wire tracing without the need for direct connection. (**Note: When using the battery booster (B2024 or B2025) the unit will work in ultra high "U-HI" mode only. Remove the battery booster to return to normal operation.**)

Fig.3 A2202 Clamp-On Transmitter Accessory



B2024 Battery Pack

24 Volt Nickel-Cadmium rechargeable cell custom designed for light weight, small size, and durability. Used to boost the output of the T-4000. Consult the specs for the boost levels. Includes a self-resetable fuse. Be sure to charge fully before use. **(DO not use the B2024 when tracing energized lines.)**

Note: When using the battery booster (B2024 or B2025) the unit will work in ultra high "U-HI" mode only. Remove the battery booster to return to normal operation.

Fig.4 B2024 Battery Pack

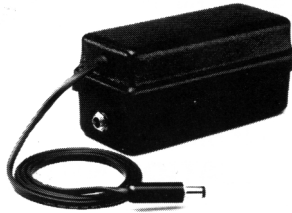

B2025 110V Converter/Recharger

Can be used to either recharge the B2024 or directly boost the T-4000. To recharge the battery, leave it connected for at least 8 hours. **(DO not use the B2024 when tracing energized lines.)**

Note: When using the battery booster (B2024 or B2025) the unit will work in ultra high "U-HI" mode only. Remove the battery booster to return to normal operation.

Fig.5 B2025 110V Converter/Recharger



C2901 Pigtail- Banana Plug Cord set

For use on 110VAC receptacles.

Fig.6 C2901 Pigtail



C2902 Alligator-Clip Banana Plug Cord set

For direct contact to bare conductors

Fig.7 C2902 Alligator

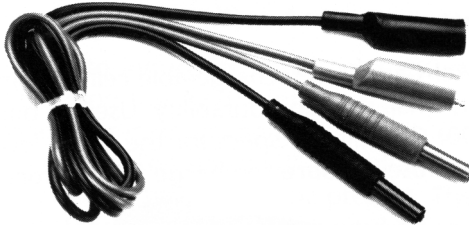

MTL-G Grounding Test lead And Alligator Clip

Fig.8 Grounding Test Lead And Alligator Clip



APPLICATION NOTES

Using the R-4000CON with Thumbwheel

1. Turn ON unit by pressing the ON/OFF push button.
2. Press MODE push button to select the sensitivity level
 - a) OPEN Tracing: LED ON
 - b) SHORT Tracing: LED OFF
3. Press SENSITIVITY push button to select the sensitivity level.
 - a) LOW Sensitivity: LED OFF
 - b) MEDIUM Sensitivity: LED Blinking
 - c) HIGH Sensitivity: LED ON Solid
4. Locate the thumbwheel on the left side of the unit
 - a) Select MEDIUM Sensitivity Level
 - b) Rotate thumbwheel counterclockwise to decrease sensitivity level
 - c) Rotate thumbwheel clockwise to increase sensitivity level

IMPORTANT: Always conclude your tracing with the “MID” or “LOW” sensitivity because the built in detector has a 360° detection range. It will be a good idea to have the transmitter on the low signal transmission depending on the length of the wire you are tracing.

5. When tracing, move the R-4000CON back and forth slowly over the path of the wire. The strongest signal confirms the path of the wire.

Fig.9 R-4000CON Receiver

In either SHORT or OPEN MODE, the unit is non position sensitive

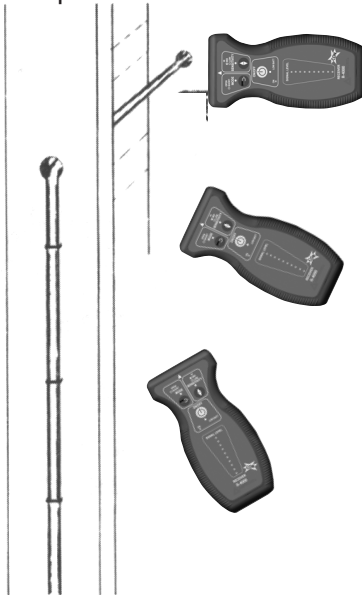

Using the T-4000 Transmitter

1. Make sure the voltage is not higher than 600V on the conductor you wish to trace.
2. Always connect the banana plugs to the T-4000 before connecting to the circuit.
3. Using the alligator clip cord set, connect the banana plugs to the transmitter.
4. Connect one alligator clip to the wire you wish to trace(it doesn't matter which one as the input plugs are not polarized) and the other one to a separate ground.
5. Turn the unit 'ON' by pressing on the ON/OFF push button- The screen should display '18888' briefly. The transmission is 'OFF'
6. Select the signal transmission level (LOW, MID, HIGH) by pressing on the signal level push button. It takes about 2 seconds for the transmission to start after you last hit the push button. (**Note: When using the battery booster (B2024 or B2025) the unit will work in ultra high "U-HI" mode only. Remove the battery booster to return to normal operation.**)
7. Trace the wire with the R-4000CON receiver. The signal will stop at the break in the wire.
IMPORTANT: When using the T-4000 in energized circuits with GFCI protection, always use the Low level transmission.

Fig.10 T-4000 Transmitter

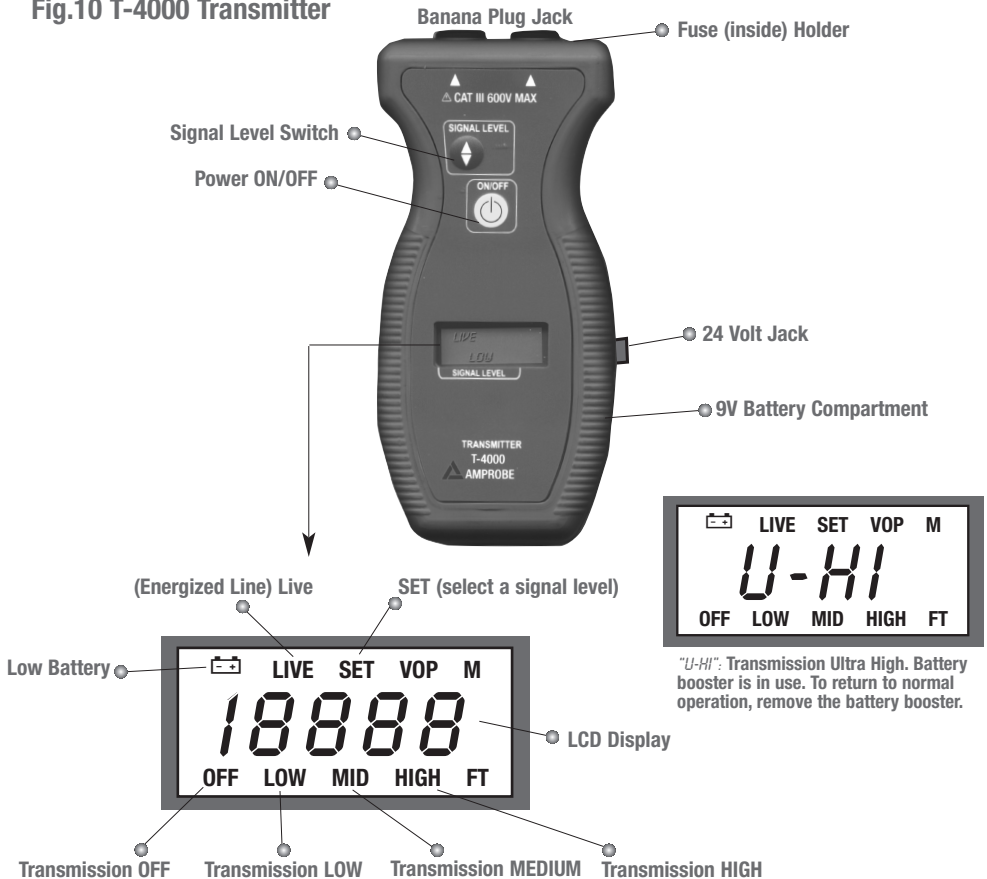

The signal generated by the T-4000 is present at all points around the circuit. The T-4000 connected to a 110V outlet via the C2901 cord set will cause an incoming signal on the neutral wire as well as an outgoing signal on the hot wire. The close proximity of these two wires may cause the signals to cancel each other, making it difficult to trace the cable in these areas. In this case, keep the R-4000CON in the high sensitivity range. (**Refer to Figure 11**)

Fig.11

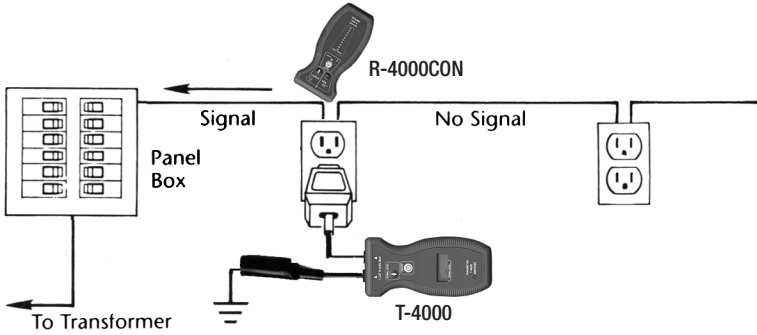

At the panel breakers, the hot wire is separated from the neutral wire (where it is grounded) allowing easy circuit breaker identification. In that case, use the Low sensitivity range of the R-4000CON. So, if tracing the branch wiring through the walls is not necessary, use the C2901 for quicker connection. (**Refer to Figure 12**)

Fig.12

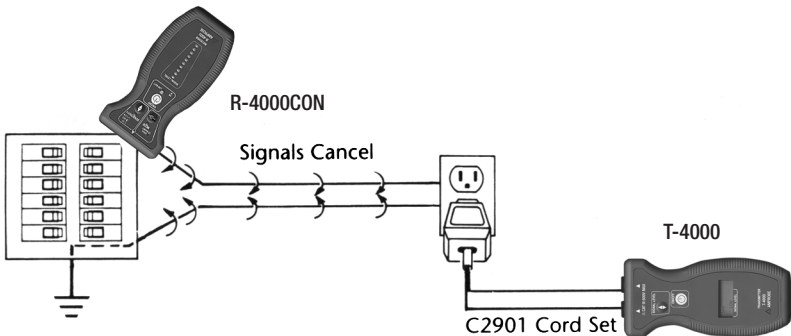

Easy tracing of wires and buried cable is accomplished by simply separating wire from the return path (ground). Instead of using the neutral wire or the conduit as the ground, use the C2902 Alligator Clip cord set and attach the grounding test lead to a separate ground such as a water pipe. (**Refer to Figure 13**)

Fig.13 Tracing Buried Cables

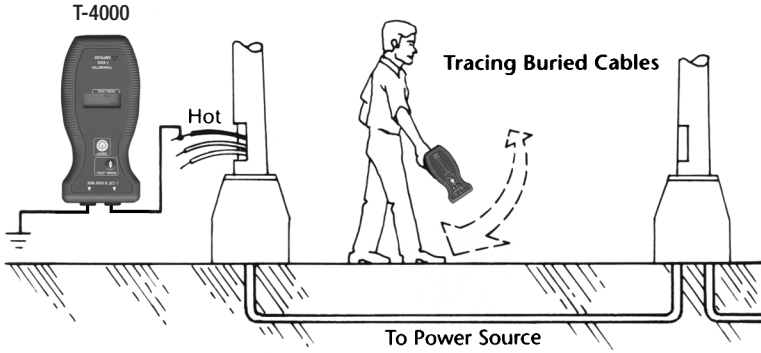

Using the A2202 Clamp-On Transmitter Accessory

The A2202 will allow non-contact signal indication onto energized or non-energized conductors. On energized lines, the signal will propagate downstream to the end of the circuit, provided there is a current flowing in the circuit. Unenergized lines must be grounded at both ends or made into a complete circuit. The signal strength can be boosted significantly by using the B2024 battery Pack. **(Note: When using the battery booster (B2024 or B2025) the unit will work in ultra high “U-HI” mode only. Remove the battery booster to return to normal operation.)**

One typical application for the A2202 is to access the hot wire at the panel in order to identify the ‘downstream’ loads:

1. Plug A2202 into T-4000. Set signal level to ‘High’.
2. Clamp the A2202 around the ‘hot’ wire.
3. Set the R-4000CON to ‘OPEN’ mode and trace the downstream wiring. To trace buried lines, switch to ‘SHORT’ mode (See *Locating Outlets From The Breakers Panel* on page 17)

Fig.14 A2202 Clamp-On Transmitter Accessory



Finding Opens

'Opens' are dead-end conductors that are not connected to anything and therefore do not pass current. To find an Open, use the T-4000 transmitter, R-4000CON receiver, and the alligator clip cord set. **(Refer to figure 15)**

1. Plug the two banana plugs into the T-4000
2. Connect one of the alligator clips or the grounding test lead to a separate ground.
3. Connect the other alligator clip to the conductor.
4. Where possible, ground any other conductors sharing the same path as the Open wire.
5. Turn the T-4000 'ON' by pressing the ON/OFF push button and select a signal level transmission by pressing the signal level push button.
6. Turn the R-4000CON 'ON' by pressing the ON/OFF push button.
7. Select 'OPEN' mode by pressing the MODE push button(the LED must be 'ON').
Note: If the conductor is buried in moist soil, the 'SHORT' mode may give better results.
8. Select the 'HIGH' sensitivity by pressing the SENSITIVITY push button (the LED must be 'ON').
9. Starting from the T-4000, trace the conductor. The open will be at the point you begin to lose signal. At that point, select the 'MID' sensitivity mode (the LED must be 'blinking') in order to pinpoint the exact location of the Open.
10. Repeat process from the other end of the wire to make sure that you trace the right wire.

If you end up tracing the entire length of the wire without locating the open, you may be experiencing capacitive coupling, or 'Signal bleed-off' onto the adjacent conductors. This condition may be alleviated by: a) grounding all adjacent conductors; b) minimizing the distance between the point of connection and the open.

If another conductor is connected to the first conductor somewhere along its length, the signal will split between them, causing both conductors to emit half the signal each. The B2024 battery or the B2025 converter can be used to increase the signal strength.
(Note: When using the battery booster (B2024 or B2025) the unit will work in ultra high "U-HI" mode only. Remove the battery booster to return to normal operation.)

Fig.15 Tracing Open Wire

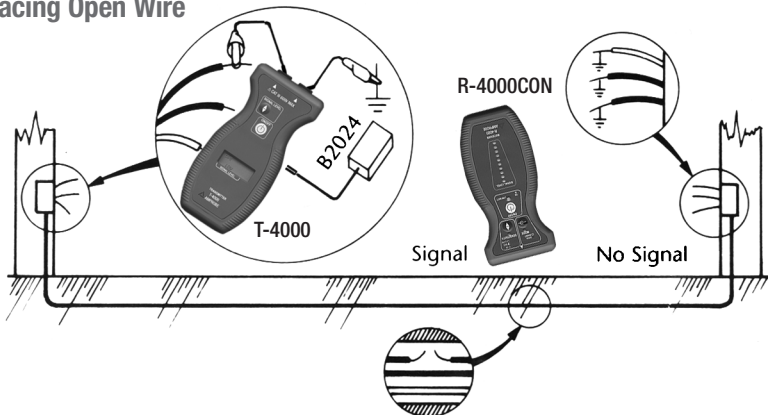

Finding Ground Faults

A ground fault is a direct connection of the conductor to ground. A typical ground fault may cause a tripped circuit breaker or a blown fuse (in contrast to an 'open', which passes no current). In this situation, the B2024 battery can be used as the current source. The high voltage from the B2024 will overcome a high resistance fault and will produce a stronger signal. Also, you can use line voltage as the power source by connecting the T-4000 across the breaker. (**Note: When using the battery booster (B2024 or B2025) the unit will work in ultra high "U-HI" mode only. Remove the battery booster to return to normal operation.**)

1. Plug the alligator clip cord set into the T-4000.
2. Attach one clip to the faulted wire and the other one to ground.
3. Press the signal level push button and select the appropriate level.
4. If possible, ground all adjacent conductors.
5. The R-4000CON receiver can then be used to trace the wire. The signal should remain relatively constant until you pass the ground fault. At the fault, the signal from the T-4000 will pass from the wire and disperse into the ground. For this reason, the signal strength will decrease gradually. Watch the LEDs carefully in order to locate the fault within a few inches. (**Refer to Figure16**)

Fig.16 Finding Ground Faults

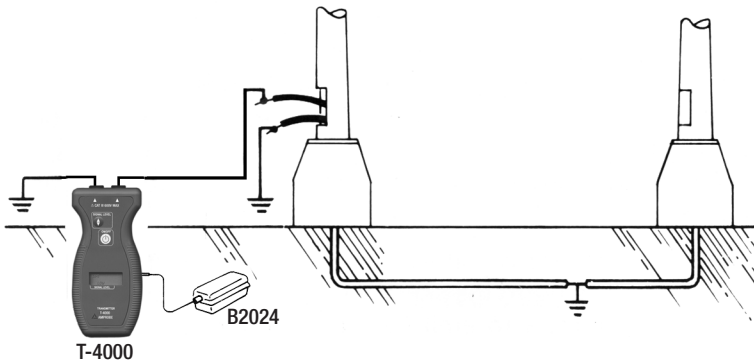

Tracing Wires in Conduit

When seeking a ground fault within metal conduit, the 'ground' is the conduit. Connect one of the clips to the conduit to complete the circuit.

Steel conduit will tend to attenuate the signal strength so tracing will require higher sensitivity levels and access to within a few feet of the conduit. Aluminum conduit will severely attenuate the signal and sometimes even blocking all the signal from the wire. It may be necessary to periodically access the wire in the conduit to confirm signal presence.

Locating Circuit Breakers Or Fuses

Caution: Always check to make sure the line voltage DOES NOT EXCEED the range of the T-4000: 9-600V

1. Connect the T-4000 to the circuit as shown in Fig.17 using either the C2901 pigtail Cord set for 110V receptacles or the C2902 Alligator Clip cord set.
2. Turn 'ON' the unit.
3. Select a signal level by pressing on "Signal Level" push button.
4. Turn ON the R-4000CON receiver.
5. Select the 'Short Range' and 'Low' sensitivity.
6. Move the Receiver in front of the outside of each circuit breaker, as shown, to determine which one has the strongest signal.
7. If two or more breakers produce the same signal strength indication. Move the receiver away slowly from each of them and watch the indication level.
(Refer to Figure 17)

Fig.17 Identifying Circuit Breakers

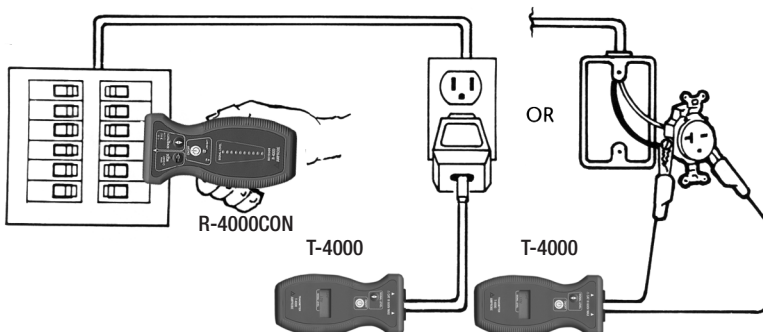

Tracing Energized Wires

1. Connect the Alligator Clip Cord set to the T-4000.
2. Make sure the voltage does not exceed the T-4000 rating.
3. Connect one alligator clip to the hot wire and the other to a separate ground. At a receptacle, use the C2901 Pigtail to access the hot wire. Use the 25-FT ground test lead to ground the T-4000. (**Make the connection as shown in Figure11**)
4. Turn ON the R-4000CON.
5. Select 'SHORT' mode.
6. Starting with Low sensitivity setting, circle the area with the R-4000CON to locate the path of the wire.

Tracing Unenergized Lines and Finding Shorts

If the wire you wish to trace is part of a complete circuit, or can be made into a complete circuit easily, use the following procedure. If it is not part of a complete circuit then use the "Finding Opens" procedure on page 13.

Follow the following procedure:

- A) Connect the alligator clip cord set to T-4000.
- B) Attach one alligator clip to the wire you wish to trace and the other one to ground.
- C) Turn ON the T-4000.
- D) Select the appropriate signal level.
- E) Turn ON the R-4000CON.
- F) Select the appropriate mode and sensitivity.
- G) Trace the wire.

Locating Individual Wires in a Bundle Energized and Unenergized Lines

1. Attach alligator clip cord set to the T-4000.
2. Verify that the voltage on the line does not exceed the T-4000 rating.
3. Connect one alligator clip to the wire you wish to identify and the other to a separate ground using the 25' ground test lead.
4. Turn the R-4000CON ON and select "Low" sensitivity.
5. Set mode to "SHORT".
6. At the bundle, pull each individual wire away from the other wires as far as possible.
7. Use the R-4000CON to detect the proper wire.
8. The strongest signal indicates the proper wire (**Refer to Figure 18**)

Fig.18

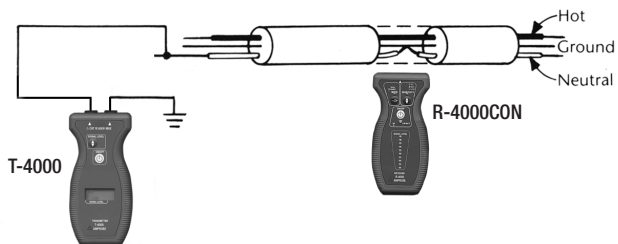

Locating Outlets From The Breakers Panel

1. Connect the A2202 Clamp-on to the T-4000 Transmitter and then clamp it around the conductor.
2. Set the T-4000 to 'HIGH' signal level.
3. Set the R-4000CON to 'OPEN' mode and 'LOW' sensitivity.
4. Hold the R-4000CON in front of each suspected outlet or piece of equipment. If it is on the same wire as the clamp, the R-4000CON will indicate it.
5. If a known outlet does not produce a signal, use the B2024 to boost the signal. (Refer to Figure 19)

Note: When using the battery booster (B2024 or B2025) the unit will work in ultra high "U-HI" mode only. Remove the battery booster to return to normal operation.

Fig.19

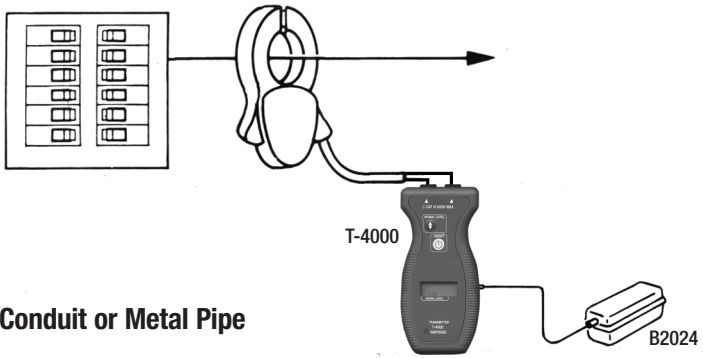

Locating Buried Conduit or Metal Pipe

1. Connect the A2202 clamp-on to the T-4000 Transmitter and then clamp it around the conduit or pipe.
2. Use of the B2024 battery or the B2025 converter is recommended.
3. Set the T-4000 to 'HIGH' mode.
4. Set the R-4000CON to 'SHORT' mode and 'LOW' sensitivity.
5. Trace the conduit. (Refer to Figure 20)

Note: When using the battery booster (B2024 or B2025) the unit will work in ultra high "U-HI" mode only. Remove the battery booster to return to normal operation.

Fig. 20

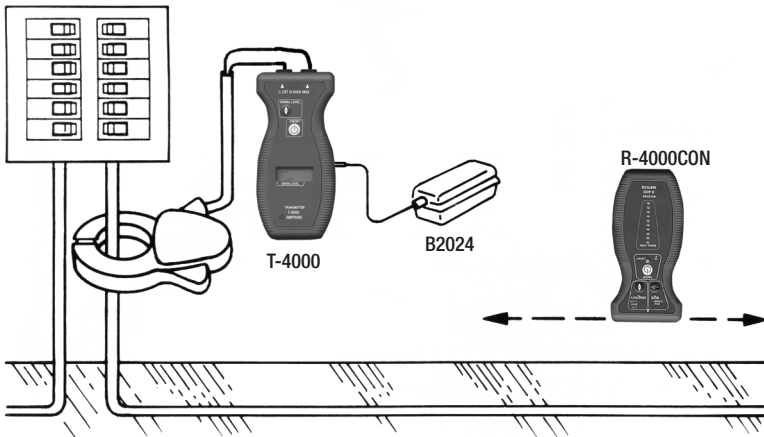

MAINTENANCE

Changing Batteries

The battery compartment on the back of the R-4000CON and the T-4000 is designed to make it easy for the user to change the battery. A screw is added to secure the battery in case the unit is dropped. A 9-Volt battery is used.

Fig.21 9V Battery



Fig.22 9V Battery



1. Remove the battery cover.
2. Install a 9V Battery using the battery clip.
3. Replace the battery cover and secure it with the provided screw.

Changing Fuse

1. Remove the battery cover of the T-4000.
2. Remove the bottom enclosure of the T-4000.
3. Remove the fuse. It is located on the upper end of the unit.
4. Use fuse replacement part #100721.
5. Close the bottom enclosure first, secure it with the provided screws.
6. Close the battery cover, secure it with the provided screw.

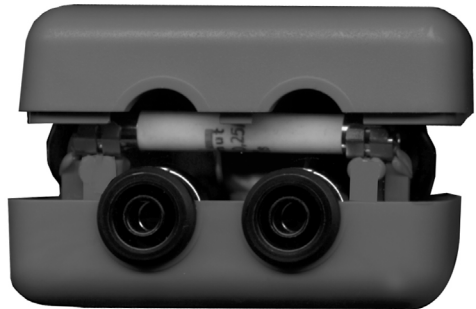

Fig.23 Fuse Location

REPLACEMENT PARTS

9V Battery.....	9V Alkaline
Clamp-On Transmitter Accessory.....	A2202
Battery Pack.....	B2024
10V Converter/Recharger.....	B2025
110V Pigtail - Banana Plug Cord Set.....	C2901
Alligator - Clip Banana Plug Cord Set.....	C2902
Grounding Test Lead 25-FT.....	MTL-G
Alligator Clip.....	VRC-320
Carrying Case AT-4000CON.....	CC-AT-4000
Owners Manual.....	www.Amprobe.com
Fuse 1000V 0.25A FA 6X46MM.....	FA6X46MM

TROUBLE SHOOTING

Symptom	Possible Cause	Solution
LCD Segments of the T-4000 are fading	9V battery is low in voltage	Replace the battery
R-4000CON Can't detect signal	a) Wrong Mode or Range b) Transmitter is OFF or the signal level is too low c) Signal Cancellation	a) Ensure that you are using the right mode or range. (See application notes) b) Turn ON the transmitter and select the appropriate signal level. c) Use a separate ground or separate the wires.

SPECIFICATIONS

General

Operating Temperature: 0 to 120° F (-18°C to 49°C)

Storage temperature: -40° to 150° F (-40° to 66°C)

Case Material: ABS

Case Size: 0.55" x 0.26" (14x6.7mm)

R-4000CON Receiver

Detectors: Electromagnetic Coil Array pick up for short mode.
Electrostatic plate pick up for open mode.

Sensitivity: Low and High programmable gain from the traced wire.

Short Mode performance: Over 20' in air from the traced wire under test conditions.

Open Mode performance: Over 12' from the traced wire in air under test conditions.

50HZ, 60HZ, and 400HZ Rejection: 120db

Power Source: 9V alkaline battery

Display: 10 LEDs

Case: Flame retardant ABS

Weight: 0.5 Lb. (113g)

T-4000 Transmitter

Operating voltage: 9-600 volts

Operating frequency: 32.768 KHZ

Duty Cycle: Transmit 2 pulses with a duration of 0.0625S each, every 0.5 seconds

Case: Flame retardant ABS

Display: LCD (Liquid Crystal Display)

Weight: 0.32 LB (143.5g)

Current Output of the Signal:

Low Mode: 11 mA average, 30 mA peak

Medium Mode: 12 mA average, 36 mA peak

High Mode: 13 mA average, 63 mA peak

Fuse: Fast acting 250 mA @ 1000V (6X46mm) **P/N: FA6X46MM**

Signal Output (9V supply):

High setting: 0.74 VAC

Medium setting: 0.61 VAC

Low setting: 0.53 VAC

Battery: 9V alkaline- 24V jack will accept battery pack accessory
(B2024 or B2025)

A2202 Clamp-on Transmitter Accessory

Operating Frequency: 32.768KHZ as supplied by T-4000

Case Breakdown Voltage: 3000 volts

Maximum Wire size: 2000 MCM or 2" dia. Cable

Battery: None, power is supplied by T-4000

B2024 Battery Pack

Type: Nickel-Cadmium rechargeable (20 AA cells)

Capacity: 24-Volt, 600 mah

Rechargeable Time: 14 hours

Fuse: internal self-resetting

B2025 Recharger/Converter

Input: 115VAC

Output: 24 VDC @350 mah



AMPROBE®

a business unit of **SPX** Corporation
www.Amprobe.com